

Artikel jurnal Internasional

by Chamdan 5

Submission date: 31-Jul-2018 08:02PM (UTC+0700)

Submission ID: 986554804

File name: 05_The_Strategic_Experiential_Models_and_Providers_In.docx (205.42K)

Word count: 6182

Character count: 36349

The Strategic Experiential Models and Providers In Improving Customer Satisfaction and Loyalty (Study Beverage Bottle Ready to Serve Tea Sosro)

Chamdan Purnama

President, Al-Anwar School of Economics Mojokerto Indonesian 61361

* Email: chamdan.p@gmail.com

Abstract

This study aims to identify and analyze how much influence the Strategic Experiential Models and Providers in improving customer satisfaction and loyalty instant tea beverage bottles sosro. The research was conducted on a sample of 171 customers sosro bottled tea drinks taken by purposive sampling technique. Through the analysis of Structural Equation Modeling (SEM) found that: First, an Experiential provider (which includes communications, visual identity, product presence, co-branding, web sites and people) positive effect on customer satisfaction and customer loyalty. Second, Experiential models (which include relate, sense, act and think) positive effect on customer satisfaction and customer. Third, customer satisfaction (include preferences, actual behavior, referencing and intentions) positive effect on customer loyalty (includes recommending and repeat purchases). Fourth providers Experiential, Experiential models and customer satisfaction simultaneously positive effect on customer loyalty.

Keywords: Experiential providers, experiential models, customer satisfaction, customer loyalty

1. Introduction

In an era of intense competition's success creates a positive perception in the minds of consumers is an important factor in the success of the sale of a product, and therefore companies need to convey or communicate a product by touching the emotional side of the consumer. Competition is so tight evident from the many tea in bottles on the market. The existence of these phenomena cause customers are faced with a wide selection of products that could eventually allow customers to switch to another brand, especially if the brand is to make a change and offer a superior product characteristics from various angles attributes.

The Company will successfully obtain the customers in large numbers when assessed to provide customer satisfaction. The creation of customer satisfaction can provide several benefits, including the relationship between companies and consumers become harmonious, provide a good foundation for repeat purchase, a form of word of mouth recommendations which benefit the company and the creation of customer loyalty (Tjiptono, 1997: 24).

Satisfied and loyal customers an opportunity to gain new customers. Retain all existing customers will generally be more advantageous than the turnover of customers because the cost of attracting new customers can cost five times more than retaining an existing customer (Kotler et al, 2000: 60). So maintaining the same customer with maintaining the viability of the company.

To keep customers need to build a new marketing strategy, Experiential Marketing is a relatively new marketing methods, are conveyed to the world of marketing. Schmitt (1999) considers the concept is very

limiting way marketers view of the decision taken by the consumer, which involves elements of rationality and logic, as well as emotional and irrational aspects of the purchase. Experiential marketing can be very useful for a company that wants to improve the brand that is on the decline stage, differentiate their products from competitors' products, create an image and identity for a company, increase innovation and entice customers to try and buy the product. The important thing is to create loyal customers. Customers are looking for companies and certain brands to be part of their lives. Customers also want the companies and brands they can relate to their lives, they understand, adapt to their needs and make their lives more fulfilled. In the information age, technology, change and choice, every company needs to be more in tune with customers and experience a given product or service.

In research Yulastuti (2006) Mc Donald's *Tunjungan Plaza* and Plaza Surabaya variable Communication, Visual Identities, Product Presence, Co-branding, Environment, People have an influence on satisfaction on consumer Mc Donald's Surabaya and with satisfaction then the consumer will always have the intention to buy Mc Donald's birthday in Surabaya. While Sanjaya (2005), Experiential Marketing examines the dimensions of product attributes, product identity, and communication that significantly influence consumer *loyalty's lux soap* products. And Sicily (2005), examines Effect of Experiential Marketing Consumer Loyalty at the Dairy Queen Supermarket Malang. Research results prove that the application of the Experiential Marketing has a significant influence on consumer loyalty to the Queen of the Supermarket milk products Malang especially on dimensional attributes have a dominant influence on consumer loyalty. According McCole (2004:535), care should be an advantage to the consumer by making consumers more so emotionally attached to the product or service. This is a new concept to ensure that the consumer experience is emotionally attached to the brand is the main goal of experiential marketing. Through a variety of marketing tactics and characteristics, the company must find a way to create a unique memorable experience for consumers to not switch to a competitor.

Based on the description above, this research will raise the issue of the extent of the application of experiential marketing in the form of Strategic Experiential Models (SEMs) and the Experiential Providers (ExPros) can increase customer satisfaction and loyalty on fast food soft drink products Tea Sosro.

2. Literature Review

2.1. Experiential Marketing

Schmitt (1999:60) states Experiential Marketing Concept focuses on two key concepts: Strategic Experiential Providers (ExPros) and Experiential Models (SEMS).

a. Strategic Experiential Providers (ExPros)

- 1) Communications and Saladin Djaslim Yevis Oesman Marti (2001: 194), Marketing Communications is a combination of the sale of advance planning, advertising, sales promotion, publicity and public relations help achieve company goals. Djasmin Saladin (2001: 123) is a marketing communications activities that try to spread information, influence and persuade or remind the target of the company and its products to be willing to accept, purchase loyal to the products offered by the company in question
- 2) Visual Identity (Visual Identity), Visual identity in the form of appearance of a product to be viewed directly by consumers. According to Schmitt (1999:78) visual identity in the form of names, logos, and signs. Kusmiati, Artini (1999:103), the term "visual identity includes a broader range which is to show the public about a characteristic, personality, glory, confidence and quality of the products or services of a company

- 3) Product Presence (Presence Products), According to Schmitt (1999:79) The presence of these products can also be used to create an experience. The presence of the product includes product design, packaging and display products, and brand character that is used as part of the packaging and point of sale material.
- 4) Co-Branding (Cooperation) Co-Branding by Palupi (in Surianto and Aisha, 2009:133), Is a collaboration between the two parties to make both products better known by the public, which established cooperation will be mutually beneficial.
- 5) Spatial Environment (Spatial Environment), Is a spatial environment where spatial Environment expression is something that can lead to the experience through the design of the room, which is designed to have aesthetic value, from the interior, floor, up the interior of the device it self.
- 6) Web Sites, Web sites are Internet sites. Web Sites is a communication tool for business and a great way to deliver information to customers or co-workers. To succeed, the website must provide extensive information and an easily digestible format, well-designed navigation and ease of operation is very important for an effective website (Siegel, 2007).
- 7) People According to Schmitt (1999:92) included in sales force, company representatives, service providers, customers, service providers and anyone who may be associated with a company or brand. A person is a medium that can interact directly with the consumer / visitor.

In this study is the use of the indicators in Communications, Visual Identity, Product Presence, Co-Branding, Web Sites, and People.

b. Strategic Experiential Models (SEMS)

- 1) Sense (Five Senses), Sense marketing trying to create a sensory experience through the five senses are present in humans (Schmitt, 1999:99), namely vision (sight), auditory (sound), olfactory (scent), taste (taste), and tactile (touch)
- 2) Feel (Feelings), Feel the touch inner feelings and emotions, targeting evoke affective experience, so there is a sense of joy and pride. Elements include the feel of the mood and feelings or positive emotions (Schmitt, 1999:118).
- 3) Think (Thought), by thinking can stimulate a person's intellectual ability and creativity. Schmitt (1999:138) says Think aims to encourage the customer are involved in an extensive and creative thinking with a company or product.
- 4) Act (act), Marketing Act was designed to create consumer experiences associated with the physical part of the body, the long-term behavior patterns and lifestyles and experiences that occur as a result of interaction with other people. (Schmitt, 1999:154).
- 5) Relate, Relate to imply a relationship with another person, other social groups (occupation, ethnicity, or lifestyle) or body, broader social more abstract such as a nation, society, or culture. (Schmitt, 1999:171). Campaign upload relate one's desire to develop themselves (e.g. "ideal person" in the future he wants). Relate marketing arouse one's desire to be viewed positively by another individual. In addition, a person relates marketing also linked with broader social system, thus creating brand relations and strong brand communities.

2.2. Customer Satisfaction

According to Kotler (2002:42) stated that customer satisfaction is a person's feelings of pleasure or disappointment that emerged after comparing the perception or impression of a product's performance or results

and expectations. As described in the definition, satisfaction is a function of perception or impression of the work and expectations. If performance is below expectations, the customer is not satisfied. If performance meets expectations, satisfied consumers. And if performance exceeds expectations, the consumer is very satisfied or pleased. With regard to satisfaction, Yahya (2002:419) express "During and after the consumption and use of products or services, consumers develop a sense of satisfaction or dissatisfaction. Consumer satisfaction is defined as the overall consumer attitudes toward goods or services after they get and use it". Satisfaction is a person's feelings of pleasure or disappointment that emerged after comparing the performance (results) the product is considered to performance (or outcome) expected (Kotler & Keller, 2007:177).

Factors that could cause customer satisfaction according to Peter and Olson (2000:158-160), among others: Hope (prior expectation), a benefit that consumers look for products (goods or services) in performing its duties. Consumer expectations formed from personal needs, the use of goods or services, word of mouth communication, and marketing activities. Performance shown by the product (product performance), which is how a product function. This component is a product results achieved in reality. In other words, consumer perceptions in measuring the results achieved by a product or service. Suitability or unsuitability of (confirmation or disconfirmation), which is the result of a comparison between prior expectations with actual performance of the product. Satisfaction or dissatisfaction (satisfaction or dissatisfaction), if performance of the product exceeds the expectations of consumers, then consumers will be satisfied. And conversely, if the product performance is worse than the expectations of consumers, then consumers will be dissatisfied.

Three common components can be identified as follows: 1) customer satisfaction is the response (emotional or cognitive), 2) the response with respect to a particular focus (eg: expectations, product, consumption experience), and 3) the response occurs at a particular time (after consumption, after selecting, based on accumulated experience, and so on). The factors that affect customer satisfaction are the quality of products and services, sales activities, and service after the sale values the company (Umar, 2002:51). From generating sales activities: (1) message (as a producer of a certain set of attitudes about the company, the products and the level of satisfaction expected by the customer), (2) attitude (as the top customer service ratings company), (3) intermediate (as top customer ratings intermediary companies. After sales services consist of activities such as warranty services and support related to feedback such as complaints handling and making money.

Satisfaction can be divided into two kinds, namely: (1) functional satisfaction (i.e. satisfaction derived from the function of a product that is used), and (2) psychological satisfaction (i.e.3 satisfaction derived from attributes that are intangible products). Customer satisfaction in addition influenced by the perceived quality of service, is also determined by the quality of the product, price and actors which are personal and which are momentary situation (Rangkuti, 2002:30). From the explanation above, it can be taken as a indicator of satisfaction is the favorite, actual behavior, references and intentions.

2.3. Customer Loyalty

Customer loyalty by Griffin (2005:4) is: "Customer loyalty is defined buying behavior revealed nonrandom purchase from time to time by some decision making unit". According Tjiptono (2000:110) says that: "Customer loyalty as a customer commitment to a brand, store, and supplier based on a very positive attitude and is reflected in the consistent repeat purchases." Meanwhile, according Widjaya (2008:6) states that: "customer Customer loyalty is the attachment to a brand, stores, manufacturers, service providers, or other

entities based on a favorable attitude and a good response as repeat purchases ". Oliver in Hurriyati (2010:129) states that loyalty is a deeply held commitment to repurchase a product or service

From the above definition it can be concluded that the more loyalty leads to behavior (behavior) compared with attitude (attitude) and a loyal consumer purchasing behavior will exhibit behavior that is defined as the purchase of a regular and show the behavior of the whole by the decision maker.

Loyal customer is an asset to the company and to find out the company's loyal customers should be able to offer products or services that can meet customer expectations and to satisfy their customers, when a customer makes a purchase action repeatedly and regularly then the customer is a loyal customer. This is reinforced by the statement from Griffin (2005:31), which states that the characteristics of loyal customers, among others: 1. Repurchase on a regular basis or regular, 2. Purchase products or services outside the lines, 3. Recommend to others and 4. Not easily affected attractiveness of competitors' products. The four characters in the indicator made variable customer loyalty.

3. Conceptual Framework

The conceptual framework of the study is intended to illustrate how the relationship between the study variables based on theory and previous studies experts. Conceptual framework models the relationship between variables in this fieldwork can be presented in figure 1 below.

Figure 1: Conceptual Framework Model Research

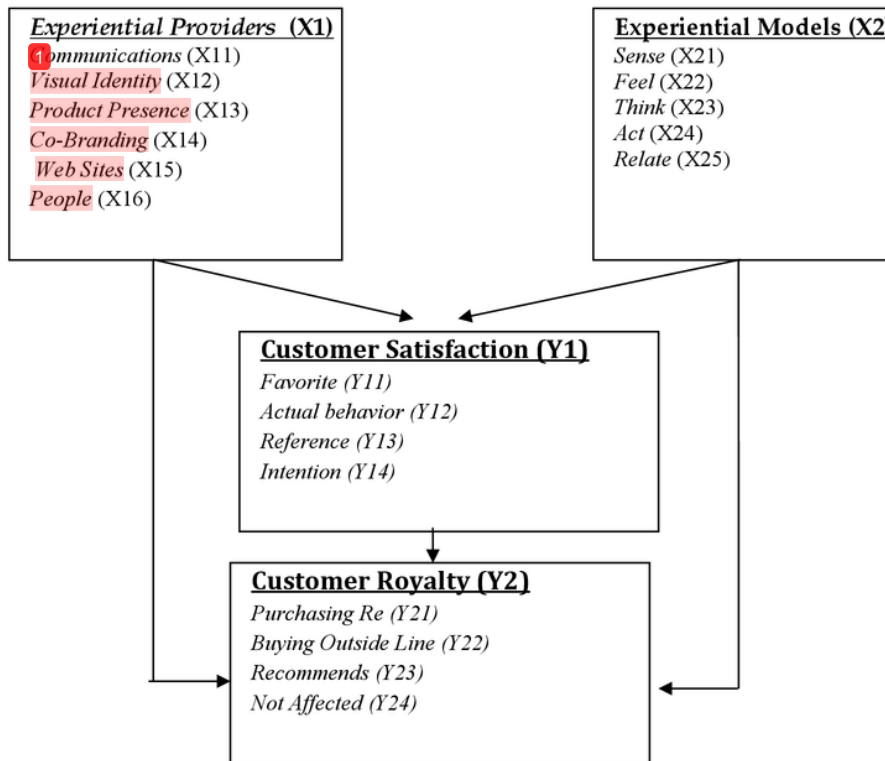

4. Research Methods

4.1. Research Design

Generally, this study aims to describe and analyze the effect of a work ethic that includes intellectual competence, task commitment, honesty and transformative ability to work Traffic entrepreneurs and small business success industry. In accordance with its objectives, the study was designed as an explanatory research. The results obtained in this study is expected to provide an explanation of how the business capabilities and business success is influenced by the work ethic of intellectual competence indicators, business commitment, honesty and transformative capabilities.

4.2. The sample

In general, samples that must be met in SEM models according to Hair et al., (1998) are numbered between 100-200 samples. Meanwhile, according to Santoso (2007:66) SEM analysis by using Maximum Likelihood estimation (ML) will be effective on the number of data samples between 150 - 400. According to Ferdinand (2005:75). Sample size criteria that can be used for SEM analysis are: (a) 100-200 samples for estimation techniques Maximum Likelihood (ML), (b) 5-10 times the number of estimated parameters, (c) 5-10 times the total number of indicator variables latent. In this study, samples taken 171 respondents, 9 times 19, where 19 is the number of indicators. Samples were taken by purposive sampling technique with the criteria of consumer never consumes at least two times and at least 17 years old.

4.3. Data Analysis

Analysis of the data using the model equations Structural Equation Modeling (SEM). SEM can be used to examine the effects of direct and indirect causality. In addition, SEM can also measure the fit model to simultaneously estimate the variance and covariance variables are logically implied by the model (Kline, in Todd, 2003).

Based on the exposure, then the model will be tested in this study are as follows:

Figure 2: Analysis Model

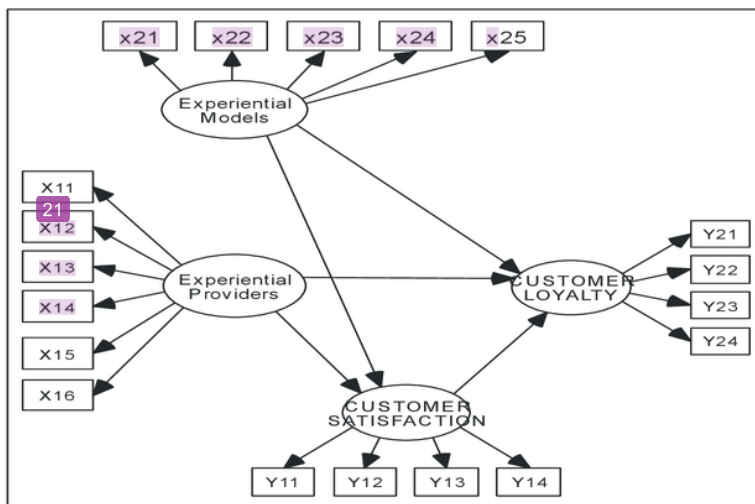

Sources: from several theories

5. Results

5.1. Testing the Conceptual Model

Test the conceptual model is intended to determine whether the conceptual model that has been developed by researchers based on theoretical studies and past research there is alignment with empirical reality. When the test results analysis produces a model that is not aligned, it will be done step by first simulation model of attention modification indices (index modification) and correlated errors (error correlation between covariance). Thus the model simulations are intended to generate empirical models that have the best degree of alignment. Test the initial model according to the conceptual model of the research, the results can be seen in Figure 3. This follows.

Figure 3: Preliminary Model Test Results

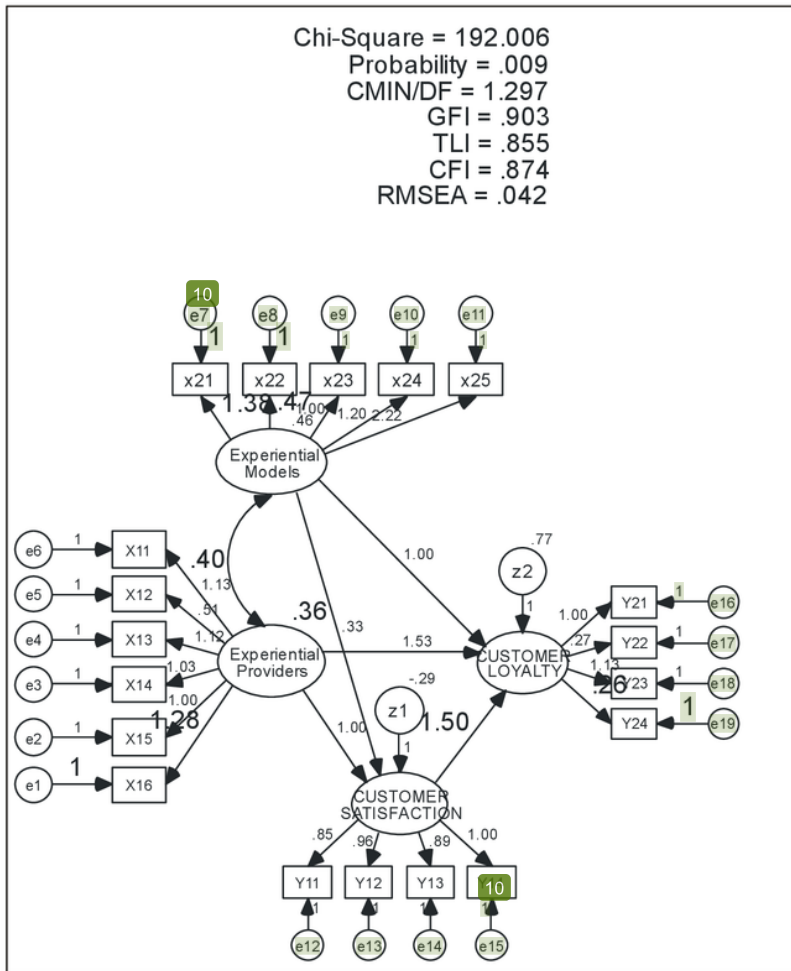

Based on the test results of the initial model in Figure 3 is not yet fully qualified coefficients obtained, the researchers conducted a modified simulation models by taking into account the modification indexes (indices modification), both based on the basic model (base model) and of correlated errors (error covariance

between mutually correlated). Requirements have not been fulfilled due to alignment models still appear under the required loading factor is <0.4 , so there needs to be modified by removing some of the indicator variables. Indicators are not eligible at this early model and need to be removed are as follows: Model experiential variables (X2), namely; feel (X22) and customer loyalty variable (Y2) i.e.; bought out the product line (Y22) and not affected competitors' products (Y24). The simulation results alignment next model is the model I looked at the stage following figure 4.

Figure 4: Model Test Results of Phase I

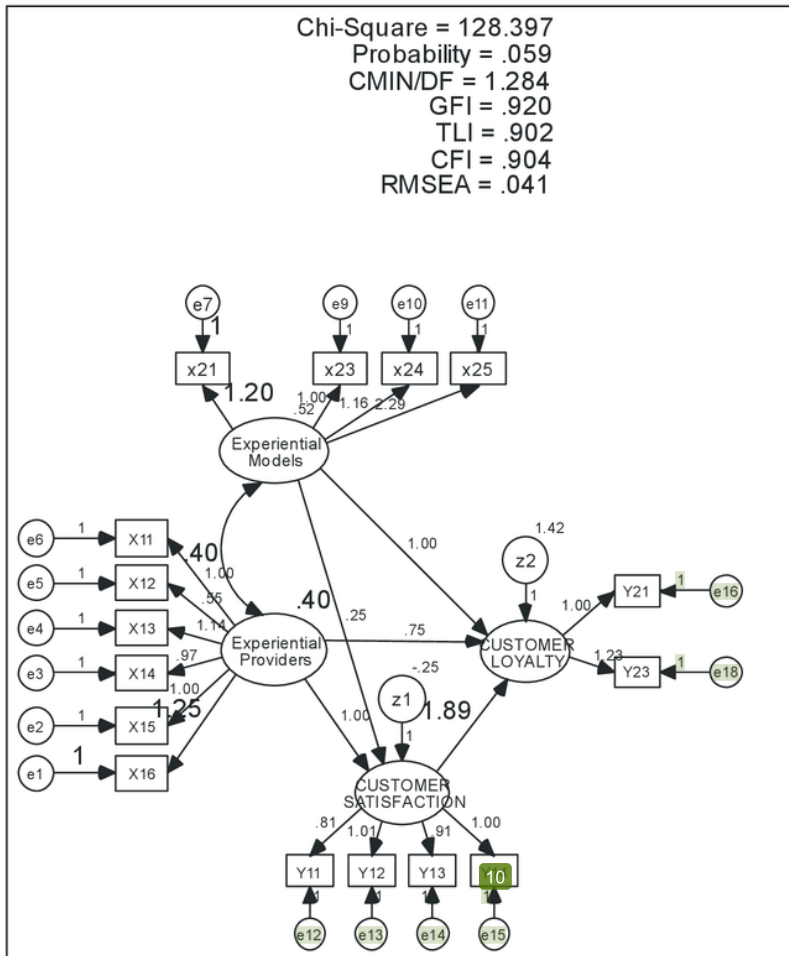

5.2. Comparison of Results of Structural Model Analysis

After showing structural models obtained from the analysis starting from the beginning according to the conceptual models, simulation models and the first stage is the final stage, it is necessary to set out a model of structural alignment value model (goodness of fit index) is best. In this study, criteria used as a basis to determine the best model is the compliance coefficient of the P-Value, GFI, TLI, CFI, RMS and fulfillment of Chi-square (X^2 with degrees of freedom (Df) is the smallest (Ferdinand, 2005). Table 1, the following is a comparison of the model coefficients alignment of the five selected models.

Table 1: Comparison of Test Results Alignment Model

Alignment Model	Criteria	Early Model	Model Phase I / Late Models
Chi Square	Small	192,006 Too big	128,397 Good
Significances Probability	$\geq 0,05$	0,009 Poor Fit	0,059 Good
CMIN/DF	$< 2,00$	1,297 Good Fit	1,284 Good Fit
GFI	$\geq 0,90$	0,903 15 Good Fit	0,920 Good Fit
TLI	$\geq 0,90$	0,855 Poor Fit	0,902 Good Fit
CFI	$\geq 0,90$	0,874 15 Poor Fit	0,904 Good Fit
RMSEA	$\leq 0,08$	0,042 Good Fit	0,041 Good Fit

Sources: Primary data were processed

Table 2: Comparison of Results of Structural Equation Models

Model	No	STRUCTURAL EQUATION
Early models	1	Customer Satisfaction = 1 Experiential Providers + 0,327 Experiential Models
	2	Customer Loyalty = 1,497 Customer Satisfaction + 1,527 Experiential Providers + 1 Experiential Models
Model Phase I / Late Models	1	Customer Satisfaction = 1 Experiential Providers + 0,254 Experiential Models
	2	Customer Loyalty = 1,891 Customer Satisfaction + 0,752 Experiential Providers + 1 Experiential Models

Sources: Primary data were processed

Noting Table 1, it was found that the model has a good alignment models, namely the model stage 1. Models of Phase I has the best alignment in terms of acquisition of the P-Value largest coefficient, CMIN / Df smallest, largest GFI, AGFI biggest, biggest TLI, CFI and RMSEA smallest largest. Determination of the second model as the best model based on insufficient alignment of the model coefficients and the resulting pattern of significant relationships between variables.

Having managed to find a new model of the findings as shown in the simulation phase of the test, the next step to test the model measurement / confirmatory factor analysis was used to determine how much the relationship between the indicator variables. Confirmatory test is done by comparing the factor loading coefficients and a significant factor in the level of probability (P) = 5%, as shown in the following presentation.

Table 3: Regression weight (loading factor confirmatory) and Critical ratio indicator

Experiential Providers

No	Indicator	Loading Factor good >0,4	Critical Ratio requirement >1,96	Probability (P) requirement <0,05	Specification
1	X11 ← Experiential Providers	1,003	2,377	0,017	Good
2	X12 ← Experiential Providers	0,550	2,079	0,050	Good
3	X13 ← Experiential Providers	1,142	2,920	0,004	Good
4	X14 ← Experiential Providers	0,966	2,623	0,009	Good
5	X15 ← Experiential Providers	1,000	2,523	0,008	Good
6	X16 ← Experiential Providers	1,251	3,019	0,003	Good

Sources: Primary data were processed

The test results are presented in the table 3 shows that when viewed from the large loading factor, that the six indicators above 0.4 by Ferdinand (2005) values are allowed to enter the loading factor in the analysis model is greater than 0.4, further Ferdinand said that while the critical ratio required to be greater than 1.96 at level $\alpha = 0.05$ and when seen from Table 3 the value of its critical ratio shows that the sixth indicator with a value significantly above the critical ratio of 1.96 and the value of the probability (P) over smaller than 0.05. From the above test results are obtained that the six indicators can be used as a measure in explaining together providers experiential variables, namely:

1. Communications (X11)
2. Visual Identity (X12)
3. Product Presence (X13)
4. Co-Branding (X14)
5. Web Sites (X15)
6. People (X16)

These six indicators are jointly able to explain the variable and of the sixth indicator variable that is most able to explain the people, then the product presence, followed by communications, web sites, co-branding and the last is the visual identity. It can be seen from the loading factor of each of these indicators as shown in Table 3

Table 4: Regression weight (loading factor confirmatory) and Critical ratio indicator Experiential Models

No	Indicator	Loading Factor good >0,4	Critical Ratio requirement >1,96	Probability (P) requirement <0,05	specification
1	X21 ← Experiential Models	1,204	3,008	0,003	Good
2	X23 ← Experiential Models	1,000	2,779	0,008	Good
3	X24 ← Experiential Models	1,161	3,377	0,001	Good
4	X25 ← Experiential Models	2,294	3,849	0,000	Good

Sources: Primary data were processed

The test results are presented in the Table 4 shows that when viewed from the large loading factor, such that only four of the five indicators that meet the above requirements 0.4 by Ferdinand (2005) values are allowed to enter the loading factor in the analysis model is greater than 0, 4, Ferdinand further said that while the critical ratio (CR) required greater than 1.96 at level $\alpha = 0.05$ and when seen from Table 4 shows that the value of its CR fourth significant indicator with CR values above 1.96 and the magnitude probability value (P) less than 0.05. From the test results obtained on four indicators that can be used as a measure in explaining variables together experiential models, namely:

1. Sense (X21)
2. Think (X23)
3. Act (X24)
4. Relate (X25)

These four indicators are jointly able to explain the variables and experiential models of the four indicators that are most capable of explaining variables relate, then sense, then act, and the most recent product and then think presence. It can be seen from the loading factor of each of these indicators as shown in Table 4

Table 5: Regression weight (loading factor confirmatory) and Critical ratio indicator Customer Satisfaction

No	Indicator	<i>Loading Factor</i> good >0,4	<i>Critical Ratio</i> requirement >1,96	Probability (P) requirement <0,05	specification
1	Y11← CUSTOMER_SATISFACTION	0,813	3,066	0,002	Good
2	Y12← CUSTOMER_SATISFACTION	1,009	3,022	0,003	Good
3	Y13 ← CUSTOMER_SATISFACTION	0,906	2,994	0,003	Good
4	Y14← CUSTOMER_SATISFACTION	1,000	2,777	0,000	Good

Sources: Primary data were processed

The test results are presented in table 5 shows that when viewed from the large loading factor, that the six indicators above 0.4 by Ferdinand (2005) values are allowed to enter the loading factor in the analysis model is greater than 0.4, further Ferdinand said that while the critical ratio (CR) required greater than 1.96 at $\alpha = 0.05$ level and if seen from Table 5 shows that the value of its CR sixth significant indicator with CR values above 1.96 and the value of the probability (P) less than 0.05. From the above test results are obtained that the six indicators can be used as a measure in explaining jointly customer satisfactions, namely:

1. Favorite (Y11)
2. Actual Behavior (Y12)
3. References (Y13)
4. Intent (Y14)

These four indicators are jointly able to explain the variable Customer satisfactions and of these four indicators are best able to explain the most dominant variable is the actual behavior, and intentions, followed most recently reference and joy. It can be seen from the loading factor of each of these indicators as shown in Table 5

Table 6: Regression weight (loading factor confirmatory) and Critical ratio indicator Customer Loyalty

No	Indicator	Loading Factor good >0,4	Critical Ratio requirement >1,96	Probability (P) requirement <0,05	specification
1	Y21 ← CUSTOMER_LOYALTY	1,000	3,066	0,000	Good
2	Y23 ← CUSTOMER_LOYALTY	1,226	6,419	0,000	Good

Sources: Primary data were processed

The test results are presented in table 6 shows that when viewed from the large loading factor, that the four only two indicators that meet the requirements above 0.4 by Ferdinand (2005) values are allowed to enter the loading factor in the analysis model is greater than 0.4 , Ferdinand further said that while the critical ratio (CR) required greater than 1.96 at level $\alpha = 0.05$ and when seen from Table 6 shows that the value of its CR second significant indicator with CR values above 1.96 and the value of probability (P) less than 0.05. From the above test results obtained that both indicators can be used as a measure in explaining jointly customer loyalty, namely:

1. Purchasing Re (Y21)
2. Recommend (Y23)

Both indicators are jointly able to explain the variable Customer loyalty and of both indicators are most able to explain the variable is recommended and then repeat purchases. It can be seen from the loading factor of each of these indicators as shown in Table 6

5.3. Hypothetical Testing Results

Results of calculations as presented in Table 7

Table 7: Results of Testing Effects of Experiential Providers and Customer Satisfaction to Customer Loyalty Against.

NO	Variable	Path Coefficient	Critical Ratio	Probability (P)
1	CUSTOMER_SATISFACTION ← Experiential_Models	0,254	2,452	0,003
2	CUSTOMER_SATISFACTION ← Experiential_Providers	1,000		
3	CUSTOMER_LOYALTY ← Experiential_Models	1,000		
4	CUSTOMER_LOYALTY ← Experiential_Providers	0,752	2,994	0,017
5	CUSTOMER_LOYALTY ← CUSTOMER_SATISFACTION	1,891	2,543	0,008

Sources: Primary data were processed

Seen from Table 7 above, the significant value of critical ratio > 1.96 and at $\alpha = 0.05$ level (Ferdinand, 2005). It is found that 1). Experiential models significantly influence customer satisfaction with a probability value (P) = 0.003 is smaller than 0.05 and 2.452 critical ratio values greater than 1.96. 2). Experiential providers significant effect on customer satisfaction with a probability value (P) and the critical ratio values are met. 3). Experiential models significant effect on customer loyalty with a probability value (P) and the critical ratio values are met. 4). Experiential providers significant effect on customer loyalty with a probability value (P) = 0.017 is smaller than 0.05 and 2.994 critical ratio values greater than 1.96 and 5). Customer satisfaction significantly influences customer loyalty with a probability value (P) = 0.008 is smaller than 0.05 and 2.543 critical ratio values greater than 1.96. The results of testing the influence of experiential providers, experiential

models and customer satisfaction to customer loyalty suggests that experiential providers affect customer satisfaction with a path coefficient of 1.000 whereas the direct effect on customer loyalty experiential providers of 0.752 and experiential influences on customer satisfaction models of 0.254. While the direct effect on customer loyalty experiential models of 1,000. Moderate effect on customer loyalty and customer satisfaction by 1.891.

6. Discussion

From the test results of structural equation modeling analysis model is found as follows: those experiential communications providers with indicator, visual identity, product presence, co-branding, web sites and people. These six indicators are jointly able to explain the experiential variables and the providers of the six indicators are most able to explain the variable is the people, then the product presence, followed by communications, web sites, co-branding and the last is the visual identity. While the indicator models include experiential sense, feel, think, act, and relate. Of the five indicators only four qualified alignment models and four models of experiential indicators are jointly able to explain the variables and experiential models of these four indicators are best able to explain the models is experiential variables relate, then sense, then act, and most Last think then product presence. For customer satisfaction indicators include A, actual behavior, reference, intentions. These four indicators are jointly able to explain the variable customer satisfaction and of these four indicators are best able to explain the variable customer satisfaction is the actual behavior, and intentions, followed reference and most recently joy. Furthermore, the indicator includes the purchase of customer loyalty, buy outside the lines, recommend and is not affected and the four indicators of the only two who were able to present indicator variable of customer loyalty and the second most dominant indicator is recommended and repeat purchases. The results of testing the influence of experiential providers and experiential models to customer satisfaction and customer loyalty suggests that experiential providers affect customer satisfaction with a path coefficient of 1.000 whereas the direct effect on customer loyalty experiential providers of 0.752 and experiential models affect customer satisfaction with a path coefficient of 0.254 and experiential influences on customer loyalty models of 1,000 was the effect on customer loyalty and customer satisfaction by 1.891.

It can be concluded that the results of this test indicate that the experiential providers and experiential models positive effect on customer satisfaction and experiential providers, experiential models and customer satisfaction has positive influence on customer loyalty. And experiential providers, experiential models and customer satisfaction simultaneously either partially or positive effect on customer loyalty

These findings indicate that the results are in line with what is uttered by Yulastuti, (2006) that that experiential providers in the form of communications, visual identity, product presence, co-branding, web sites have an influence on consumer satisfaction and satisfaction with the consumer will always have the intention to buy again. This finding is also in line with research Sanjaya (2005), Experiential Marketing examines the dimensions of product attributes, product identity, and communication loyalty's significant effect on consumers. Likewise Sicily (2005), examined the Loyalty Effect of Experiential Marketing Consumer Products. Research results prove that the application of the Experiential Marketing has a significant influence on consumer loyalty.

Associated with proven customer satisfaction has an influence on customer loyalty. The results of this study are supported by the results of research conducted by Zhilin and Peterson (2004:814) which revealed that customer loyalty can be done by increasing customer satisfaction. So, to create customer loyalty, companies must improve customer satisfaction first. This is supported by research conducted by Edward and Sahadev

(2011:339) who states that customer loyalty is influenced by customer satisfaction. These results support panelitian Assael (1998:54) argues: "Satisfaction Reinforces positive attitudes toward the brand, leading to a greater likelihood that the same brand will be purchased again. Dissatisfaction is Likely to lead to negative brand attitudes and lessens the likelihood that the consumer will buy the same brand again"

Behind these findings prove that the strategy in the form of experiential marketing experiential providers and the most effective models used for beverage companies ready to increase the papal consumers and increase consumer loyalty.

7. Conclusion

Based on the research and discussion that has been done above, it can be concluded as follows:

1. Experiential providers (as seen from the communications, visual identity, product presence, co-branding, web sites and people) positive effect on customer satisfaction and customer loyalty. Thus, to improve customer satisfaction (A, actual behavior, and intentions reference) and increase customer loyalty (recommend and re-purchase) then the First, people are required flexible marketing personnel who have the ability to make consumers amazed, intrigued and want to buy it. Second, it requires the presence of product includes product design, packaging and display products, and good characters and interesting brands that consumers are interested in either of raw materials and of zoom. Third, it is necessary to communications with consumers to spread information, influence and persuade with excess inform consumers of the products will be willing to accept at least try. Fourth necessary quality web sites with a website company can perform two-way interaction with customers, so the company can figure out what is desirable and what is not desired by consumers. Fifth, it is necessary to co-branding is the cooperation between the two parties to make a product so that the product can be obtained in accordance with the wishes of consumers. Fifth, visual identity needed because consumers will also be affected by the appearance of a product display will convince consumers to buy a product and will increase customer satisfaction
2. Experiential models (which include relate, sense, act and think) positive effect on customer satisfaction and customer loyalty. Thus, to increase customer satisfaction (includes A, actual behavior, and intentions reference) and increase customer loyalty (which includes recommending and re-purchase) then the First, arouse one's desire necessary to relate that create brand relations and a strong brand communities so that consumers confident and interested in buying the product. Second, it requires a good product that can be perceived either by sight or sense (sight), auditory (sound), olfactory (scent), taste (taste), and tactile (touch) so. Third, it is necessary to act with a well-behaved and product marketing can influence consumers to believe and are willing to buy the product. Fourth, think the products marketed are such that they can create the perception that good for consumers so that consumers are confident and willing to buy it.
3. Customer satisfaction (includes A, actual behavior, and intentions reference) positive effect on customer loyalty (includes recommending and repeat purchases). Behind these findings suggest that aspects of customer satisfaction has an important role in affecting customer loyalty in the beverage product.
4. Experiential providers, experiential models and customer satisfaction simultaneously positive effect on customer loyalty

References

- Assael, Henry, 1998, *Consumer Behavior and Marketing Action*, 6th Edition, New York University.
- Djaslim Saladin, 2001, *"Marketing Management, Analysis, Planning, Implementation and Control"*. Publisher: Lindakarya, Bandung.
- Edward Manoj, Sahadev Sunil, (2011) *"Role of switching costs in the service quality, perceived value, customer satisfaction and customer retention linkage"*, Asia Pacific Journal of Marketing and Logistics, Vol. 23 Iss: 3, pp.327 - 345
- Ferdinand, A., 2005. *Structural Equation Modeling In management research applications Elaborate Models in research for the thesis along with the S-2 and S-3*. Agency for the University of Diponegoro.
- Ferdinand, Augusty T., 2005, *"Structural Equation Modeling in Management Research"*, BP Undip: Semarang.
- Griffin, Jill, 2005. *Customer Loyalty-Grow and Retain Customers Kesetian*.
- Hair, J. F., R. E. Anderson, R.L. Tatham and W. C. Black, 1998. *Multivariate Data Analysis*. Fifth Edition. New Jersey: Prentice-Hall, Inc.
- Klein, BD2001: User perceptions of the data quality: Internet and traditional text sources, accessed on 23 February 2012 is available at the journal of computer information system: 41 (4) 0.9 to 18
- Kotler Philip, 2000. *Marketing Management: Analysis, Planning, Implementation and Control*. Prentice Hall Int, Inc., Millennium Edition, Englewood Cliffs, New Jersey.
- Kotler Philip, Gary Armstrong and, 2001. *Principles of Marketing*. Prentice Hall Int, Inc., Ninth Edition, Englewood Cliffs, New Jersey.
- Kusmiati, Artini R et al. (1999). *Teon 'Basic Communication Design Vrsual*. Jakarta: Djambatan
- McCole, P. (2004). Refocusing marketing to reflect practice: The changing role of marketing for business. *Marketing Intelligence & Planning*, 22 (5), 531-539.
- Oliver, Richard L., 1993, *"Cognitive, Affective and Attribute Base of the Satisfaction Response"*, Journal of Consumer Research, p.18-30.
- Surianto, Agung and Aisha, Nurul, 2009. Application of Experiential Marketing Strategic Influence Of Satisfaction. *Logos Journal* Vol. 6, No.. 2. University Muhammadiyah Gresik
- Peter, J.P. and Jerry C. Olson, 2000. *Consumer Behavior. Volume I and II: Consumer Behavior and Marketing Strategy*, New York: McGraw
- Rangkuti, Freddy, 2002. *Measuring Customer Satisfaction*. Jakarta: PT Gramedia Pustaka Utama.
- Sanjaya, 2005, Effect of Experiential Marketing Variables Against Consumer Loyalty Of Lux Soap In Student Islamic University of Malang. Thesis, Faculty of Economics, Islamic University of Malang,
- Santoso, SS., 2007. *SPSS Multivariate Statistics*. First Printing. Jakarta: PT Elex Media Komputindo.
- Schmitt, Bernd H. 1999. *Experiential Marketing: How To Get Customer to Sense, Feel, Think, Act, Relate to your company and brands*. New York: The Free Press
- Siegel, Sidney, 1997. *Non Parametric Statistics For Social Sciences*. Jakarta; PT. Scholastic Press
- Sicily, 2005, Effect of Experiential Marketing Of Consumer Loyalty At Dairy Queen of the Supermarket and Department of Malang. Thesis,

Sicilia Sawitri, et al. (1997). *Tailoring*. Yogyakarta: Yogyakarta Teachers' Training College

Tjiptono, Fandy, 1997, *Principles of Total Quality Service*, Fourth Edition, Publisher Andi, Yogyakarta

Umar, Husayn, 2002. *Market Research and Consumer's behavior*. Jakarta: PT Gramedia Pustaka Utama.

Yahya, D.K. (Tr.), 2002. *Consumer Behavior*. 5nd. Edition. Mowen, John C. and Minor M. New York: McGraw.

Yevis Marty Oesman and Djaslim, Saladin. , 1991. *Digest unsurunsur Marketing & Marketing*, Second Printing, CV. Linda's work. Bandung.

Yuliasuti, Hilda, 2006, *Effect of Experiential Marketing Implementation Of Satisfaction And Its Impact On Repeat Purchase Intentions In Mc Donald's Tunjungan Plaza and Plaza Surabaya*. Article.

Artikel jurnal Internasional

ORIGINALITY REPORT

18%

SIMILARITY INDEX

16%

INTERNET SOURCES

2%

PUBLICATIONS

8%

STUDENT PAPERS

PRIMARY SOURCES

1	stie-alanwar.academia.edu Internet Source	4%
2	researchleap.com Internet Source	3%
3	www.ijbhtnet.com Internet Source	2%
4	Submitted to Westminster International College - Kuala Lumpur Student Paper	1%
5	Submitted to Auckland Institute of Studies at St. Helens Student Paper	1%
6	shodhganga.inflibnet.ac.in Internet Source	1%
7	jurnal.stiekesatuan.ac.id Internet Source	1%
8	eprints.ums.ac.id Internet Source	1%

9	305ak.my.scripedita.com Internet Source	1%
10	documents.mx Internet Source	<1%
11	acikerisim.deu.edu.tr Internet Source	<1%
12	repository.unimal.ac.id Internet Source	<1%
13	isiem.net Internet Source	<1%
14	ejournal.unsrat.ac.id Internet Source	<1%
15	Handayani, P.W., A.N. Hidayanto, A.A. Pinem, I.C. Hapsari, P.I. Sandhyaduhita, and I. Budi. "Acceptance model of a Hospital Information System", International Journal of Medical Informatics, 2017. Publication	<1%
16	www.rassweb.com Internet Source	<1%
17	Submitted to University of Edinburgh Student Paper	<1%
18	Submitted to Coventry University Student Paper	<1%

19

Shuiqing Yang. "Understanding B2B customer loyalty in the mobile telecommunication industry: a look at dedication and constraint", Journal of Business & Industrial Marketing, 2015

Publication

<1%

20

Zhijian Huan, Xiaoli Xu, Huaizu Li. "The impact of service quality, satisfaction, value and switching barrier on customer loyalty in Chinese mobile telecommunication industry", Proceedings of ICSSSM '05. 2005 International Conference on Services Systems and Services Management, 2005., 2005

Publication

<1%

21

www.slideshare.net

Internet Source

<1%

Exclude quotes On

Exclude matches < 12 words

Exclude bibliography On